

CNC Aluminum Hop Up Chamfer V2 INSTRUCTION

NEXXSPEED

COPYRIGHT © 2024 NEXXSPEED®

1 CNC ALUMINUM HOP UP CHAMFER NS-HUHI002

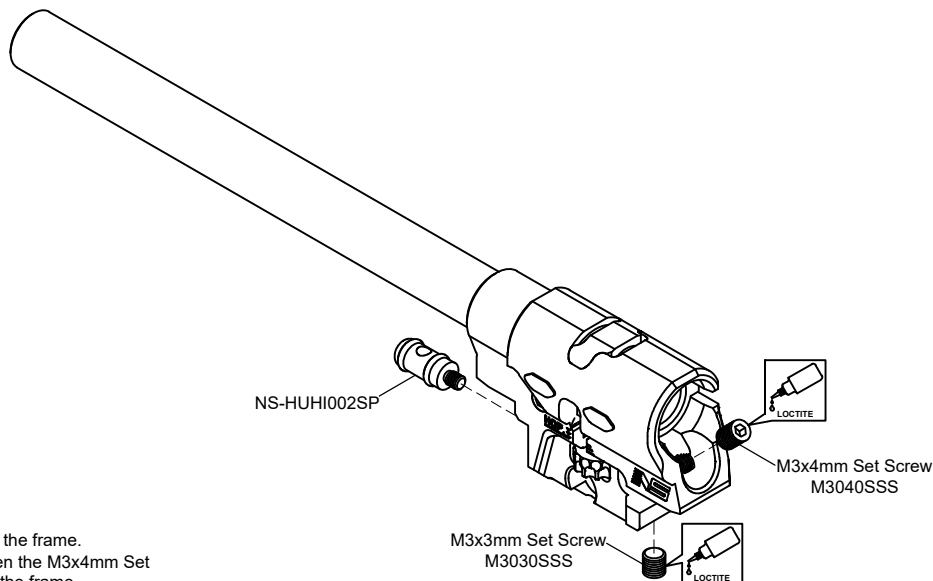
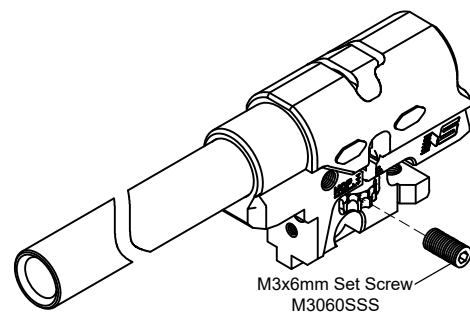
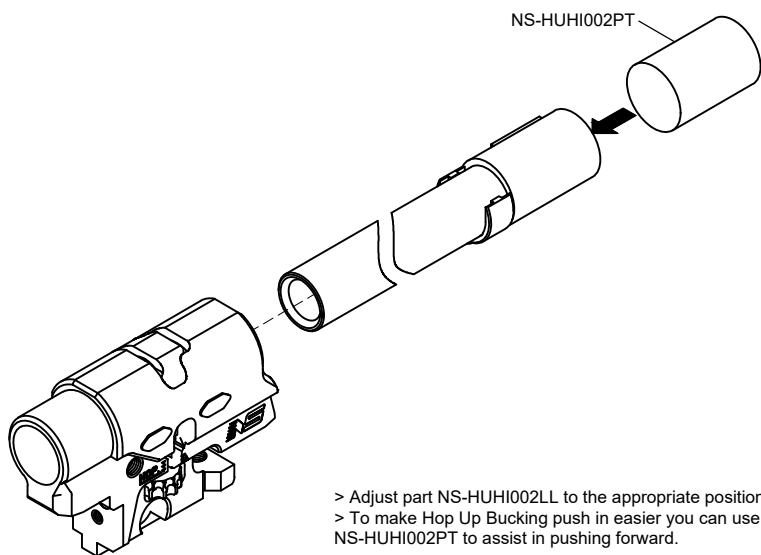
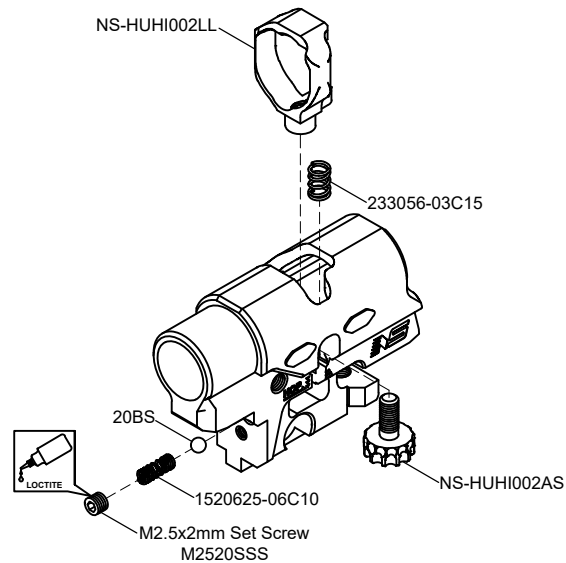
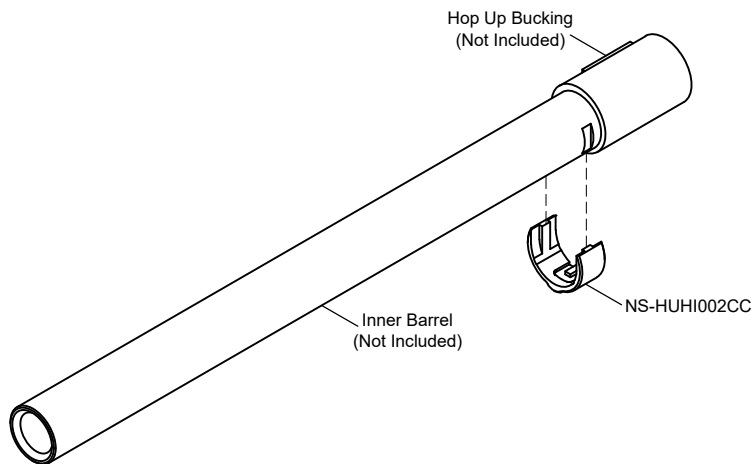

- > Part NS-HUHI002SP for 1911.
- > Adjust M3x3mm Set Screw to fit the frame.
- > After complete installation, tighten the M3x4mm Set Screw to hold the hop up firmly to the frame.



CAUTION: Please check your model carefully before functioning!

REV. HIHI002-121224-01